

# ZA10RJE

## ARTICULATED BOOM LIFT

Comply with CE/ANSI/GB Standard

### Highlights

- Powerful AC motor and drive system with on board control: precise, reliable and maintenance free
- Independent auxiliary power system for more secure application
- Best in class work height, 21.45 m, and lift capacity, up to 250 Kg

### Features

#### Standard

- Proportional controls
- All motion alarm
- Flashing beacon
- Self-closing entry rod
- Autobrake system
- Emergency descent system
- Emergency stop button
- Auto-leveling system
- On-board diagnostic system
- Over tilt protection system
- Solid seamless tire
- Load sensing system
- 4.3' LEAD display
- Horn
- Timer
- Jib rotation
- Vertical lifting function
- Thumb joystick for steering
- 35A battery smart changer
- Electric quantity display
- Low electric quantity protection





# ZA10RJE

## ARTICULATED BOOM LIFT

Comply with CE/ANSI/GB Standard

### Technical data

<b>Model</b>	ZA10RJE
<b>Size</b>	
Work Height	11.55m
Platform Height	9.55m
Horizontal Outreach	6.85m
Up and Over Height	4.6m
A - Stowed Length	5.5m
B - Stowed Width	1.19m
C - Stowed Height	1.98m
D - Platform Length	1.17m
E - Platform Width	0.76m
F - Wheelbase	1.65m
G - Ground Clearance	0.1m
Jib length	1.24m
Transport Length (jib tucked under)	3.95m
Transport Height (jib tucked under)	2.45m
<b>Performance</b>	
Platform Capacity	230kg
Drive Speed	5km/h
Gradeability	35% (19°)
Axles Oscillation	-
Turning Radius (Inside)	1.7m
Turning Radius (Outside)	3.25m
Jib Swing	355° non-continuous
Turntable Swing	±90°
Platform Rotation	±90°
H-Tail Swing	0m
Max. Working Slope	-
Max. Wind Speed	12.5m/s
Tire	22x7x17.75 seamless tire
<b>Power</b>	
Battery	24x2V/330Ah
Charger	48V/35A
Drive Motor	AC 32V/3.3kW
Lift Motor	DC 48V/4.5kW
Auxiliary Power	Electric pump DC
Hydraulic Tank Capacity	15L
<b>Weight</b>	
Gross	6550kg

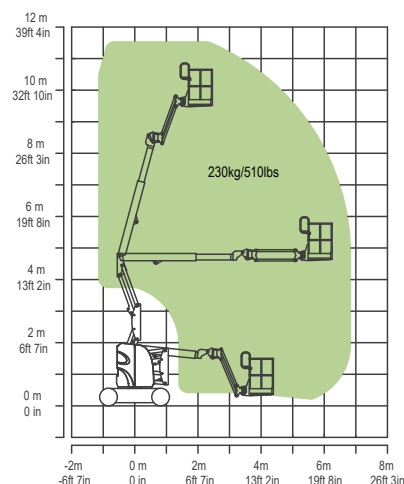
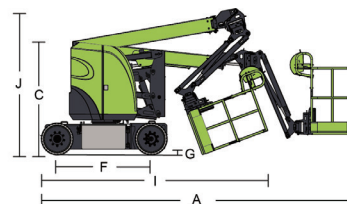

Range of Motion ZA10RJE

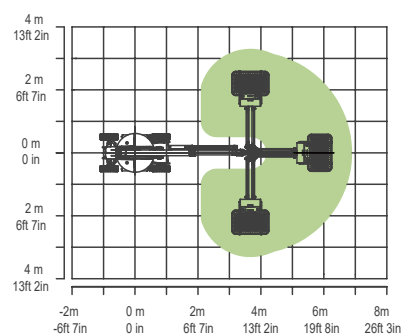

Range of Jib Swing Motion ZA10RJE